

Power Conservation, Improved Control, and Equipment Protection with Drive Output Synchronized Closed Transition

Gene E. Keyser, Ph.D.
Key Solutions, Inc.
February 2009

Abstract

Whether large or small pumps, there comes a debate when multiple drive motors are used to cover a broad range of output flow requirements: use one Variable Frequency Drive (VFD) plus a number of softstarts, some small and some large pumps with or without VFD's, one or more VFD's on a group of pumps, and all combinations in between. Equipment rotation and maintenance, starts per hour, starts per day, minimum flows, maximum demands, etc., all are considerations and decisions to be made. Many of these combinations invoke unintended hydraulic consequences.

The focus of this paper is the benefits of synchronous, closed transition hand-off between VFD's and utility powered devices in multi-motor applications. Using off-the-shelf, standard, available equipment that can synchronize drive output with across-the-line loads, the best of numerous options can be had while reducing power costs, protecting personnel and equipment, and achieving process control.

Background

The use, and abuse, of Variable Frequency Drives (VFD's) can be generally linked to the separation of system design from perspectives of electrical, maintenance, and hydraulic performance. Key elements in a proper overall system design address the following hazards:

- Check valve behavior – water hammer
- Momentum and energy shock/pressure wave
- Control gap
- Electrical phasing, regeneration v. field flux
- Efficiency – losses to heat, harmonics locally and at the point of common connection
- Equipment rotation and maintenance
- Hardware real estate

In order to achieve the following benefits:

- Protection of piping, pumps, and motors from physical water hammer damage
- Maximum installed capacity utilization
- Power factor management with optimized efficiency
- Harmonics minimization, elimination, and control
- Operational and maintenance simplicity

From the perspective of hydraulics, liquid distribution systems are well defined and much studied. Entrapped air or other gases act as restrictions and can be eliminated by system design, usually everyone's biggest concern, and operating costs can be reduced from the increased pumping costs they impose upon a piping network. Eliminating the gas traps, however, opens the door for more serious problems. When moving liquids, by definition appreciably non-compressible fluids, the Laws of Conservation of Momentum come into play. A 30" i.d. pipeline 1000 ft. in length will hold 153 tons of water. With liquid moving at just 4 ft/sec, stopping the flow in one half of a second with a valve is roughly equivalent to stopping a mid-sized, 2 ton vehicle travelling at 210 miles per hour. The two have the same momentum – reason enough for concern? With compressible gas bubbles so carefully excluded, there is little to buffer the impact except the plumbing and hardware. Smaller

line sizes and shorter lay lengths diminish the risks but they cannot be ignored;¹ proper selection and configuration of the VFD can control and even eliminate the risk.

Water Hammer Formula:^{2,3,4,5} $\Delta P = (0.070) (V) (L) / t + P_1$

Where ΔP = Change in pressure

P_1 = Inlet Pressure

V = Flow velocity in ft/sec

t = Time in sec.(valve closing time)

L = Pipe Length in feet

0.07 = friction loss, wave form, and propagation correction factor

In the example given above, an unrestricted check valve closing in ½ second on a flow of 8810 gpm at 40 psi generates a pressure wave peaking at about 600 psi. The pressure waves associated with water hammer can be compared to voltage spikes in the unfiltered output of a VFD. While the average, or root mean square (RMS) voltage is phase balanced and all but the most sensitive detection shows the prescribed motor voltage, without filtering or other controls in place the motor leads require additional protection from the high voltage spikes generated by the VFD. The system pressure gauges similarly do not show the pressure spikes, but the high pressure spikes, just like the high voltages, must be considered nonetheless.

Of no less concern from the hydraulic perspective should be the changes in momentum sent down the pipeline by changes in liquid velocity from additional pumps going on- or off-line, essentially a pressure or shock wave. How transitions from off-to-on are addressed is only of slightly less concern than transitions from on-to-off – these transitions are the extremes of the range zero to full speed and full speed to zero – but pressure waves are created by any sudden change in velocity or pressure. With check valves opening or closing in the order of a second or less against operating pressure in the line, pressure waves of several hundred psi are not uncommon. In long transmission lines operating at high pressure with fast valve actions, add a zero to the resulting pressures and to the potential bill for damages.

Separate, and in addition to the on/off transitions in the flux between hydraulic and electrical design issues, is the potential for control gaps in a multiple pump system. For this discussion, control gap is defined as the range of desired liquid flow rate that is greater than one pump can deliver and less than two pumps can deliver. In its simplest exposure, one pump delivers “x” flow rate; adding a second pump at full speed delivers “2x” minus some friction and efficiency losses. Less obvious in practice with VFD’s, a gap can exist between the flow with one or more pumps online and an additional pump at minimum speed. The latter situation is most frequently caused by control logic that starts the added pump at a fixed minimum speed regardless of the flow delivered at that minimum speed or because of the fear of running the motor below its “minimum speed.” Minimum motor speeds are chosen primarily because heat accumulates over time when operated below their “minimum” speed, actually the minimum speed is that speed required for the cooling mechanism to function well. This operating criterion cannot be ignored but it can be easily dealt with by proper

¹ If the concept of water hammer is difficult to comprehend, consider the wind instruments and their differences; an alto saxophone to the extreme of a bass tuba or various flutes to a pipe organ where the frequency and magnitude of the source changes only slightly but have enormously different output profiles. The physics of pressure waves in air and water are governed by the same rules.

² See “Tech Brief” at <http://www.plastomatic.com/water-hammer.html> for this simpler version of the more extensive discussion at <http://www.lmnoeng.com/WaterHammer/WaterHammer.htm> based upon references therein.^{3,4,5}

³ Chaudhry, M. Hanif. 1987. Applied hydraulic transients. Van Nostrand Reinhold Co. 2ed.

⁴ Fox, J. A. 1989. Transient flow in pipes, open channels and sewers. John Wiley and Sons.

⁵ Glover, T. J. 1996. Pocket Ref. Sequoia Publishing Inc. 2ed.; Hwang, Ned H .C. and Robert J. Houghtalen. 1996. Fundamentals of hydraulic engineering systems. Prentice Hall; Wylie, E. Benjamin and Victor L. Streeter. 1978. Fluid transients. McGraw-Hill International Book Co.

configuration and starting or shut down control logic. The reverse gap, going from two pumps to one in service, is more of concern as the check valve or other back pressure control is usually faster on stopping than starting. A 10% control gap can easily result in pressure waves of hundreds of psi transmitted up or down the line.

From the perspective of electrical design and coordinated implementation, the most grievous concern is the system's behavior on transient loss of power, whether by design in on/off transitions, handoffs to and from VFD and across-the-line contactors, or the infamous "power blip," the unexplained spike or loss of power that sends phase monitors, VFD's, other electronics, and operators, into apoplexy. Control and check valves should close quickly enough to prevent reverse flow through pumps, but not so fast as to create serious water hammer. Directly related to the piping arrangements, operating pressures and the length of the transients should be considered in the setup and control of the drive. Whether to shut down completely and restart after a "full stop" or resume powered operation "on the fly" is a function of the hydraulics, the electronics, and primarily the duration of loss of power.

Hydraulic protection, control, and energy issues come together when check valves that are heavily weighted artificially inflate the horsepower requirements. It is not unusual to find as much as 25% of the pumping energy in a facility consumed by the pressure losses of over-weighted check valves. In the 30" line example above, a full open check valve has an equivalent line length of 175 ft. – more normally found at ½ to ¼ open, its equivalent length is 1000 – 2000 ft. Typically the design losses for check valves are 2 – 4 psi, 5 – 9 ft of head loss; in the field, 5 – 9 psi is not unusual. In the example above at 4 ft/sec, 8810 gpm, that's 25 to 45 hp wasted; \$16,700 - \$29,300 annually.

Discussion

Properly designed and configured, the best of all worlds can be had in VFD controlled systems. The hydraulics can be operated smoothly and the electrical gear and electronics can be protected – simply, effectively, and economically.

The type of check valves to be used, if actually required at all, is application specific and should be installed in a manner to control the rate of closure. Neither too fast as to cause water hammer nor so slow as to allow reverse flow, the imperative that check valves provide minimal resistance to pumped flow has significant economic impact. In most applications a properly controlled, actuated valve is more appropriate than a check valve and more economical to own and operate. In the case of higher pressure or longer lines, use of actuators which automatically close on loss of power may be worth the slightly higher cost,⁶ particularly when considering pumping efficiency. The potential for reverse flow exists if the valve cannot close in time, but in many cases reverse flow is acceptable as long as restarting is controlled by timing or by programmable logic. For the electrical "blips," motor restart should sense motor load and act accordingly, synchronizing and controlling the output of the drive so as to not overload nor over-torque the motor.

VFD selection, and the electrical design, can take advantage of the drive characteristics to eliminate water hammer and control gaps, thus eliminating the risk to electrical equipment and plumbing, while improving the system efficiency and reducing the footprint of the electrical equipment. Consider three designs as shown in Figures 1 - 3.

⁶ If the control valve replaces both the check valve and the manual isolation valve normally used, the net cost can be significantly less, not greater.

Figure 1.

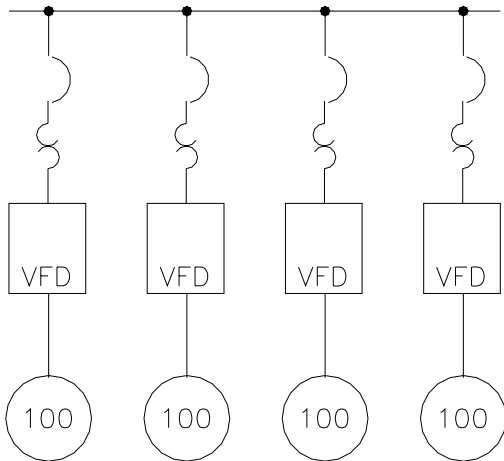

The design in Figure 1 shows the traditional “cut and paste” approach, one drive per pump, an extension of softstart or across-the-line logic. The range of capacity available is from one pump at minimum speed to four pumps at maximum speed. At typical VFD efficiencies, 3 – 4% electrical losses in the form of heat and harmonics (which ultimately becomes heat) will be incurred and corresponding air conditioning needs to be provided. The net real power requirement at capacity is nominally⁷ 109% of the power sent to the motors; in the present case, this would total 336 kW to send 400 hp to four 100 hp motors instead of 299 kW.

The design in Figure 2 is a mixed approach, two pumps with VFD’s, two with softstarts having internal

bypass functionality. At capacity, power consumption to send 400 hp is better at about 319 kW given only minimal losses from the softstarts. The latter will have a smaller footprint and a somewhat lower capital cost. The trade-off between designs 1 and 2, however, lies in unavoidable water hammer and in fact the pumps, by definition, will not be used equally resulting in varied maintenance schedules and varied wear and tear. Several scenarios demonstrate this design flaw. As flow increases from one VFD driven pump rising to maximum output followed by a pump with softstart, the timing of the transition has the VFD slowing down as the softstart ramps up with water hammer generated from the VFD pump; if the softstart leads the decreasing VFD, a high pressure wave is generated anyway. As the flow decreases from two pumps to one, the converse is true and the softstart pump’s check valve is driven closed by the rapidly increasing VFD. Because the load on the motors, the flow rates, and the pressures are not reproducible across time, there is an inevitable water hammer, minor or severe, but inevitable.⁸

Figure 2.

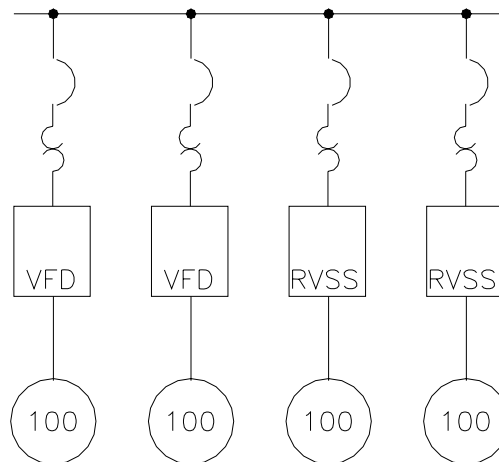

⁷ With cooling available at 50% efficiency, $100\%/97\% + 3\%/50\% = 103\% + 6\% = 109\%$. This specifically does not include the motor efficiency nor does it include the efficiency of the pump or positive displacement blower. Further, it does not include any power factor correction with respect to actual operating costs.

⁸ It is possible to achieve a smooth transition through automation, but at some operating expense. The softstart can be brought on-line dead-headed against a control valve. As the valve opens, the VFD, still operating and in control, will wind down to offset the timing and pressure delivery of the opening softstart’s valve. Once the softstart pump is fully on-line, the VFD controlled pump has reduced load and can be ramped up to meet increasing demand. In reverse, when demand is decreasing, however, there is additional complexity. The VFD pump must be brought up to minimum speed against a closed control valve. Once at speed, the VFD’s valve is opened as the softstart control valve is closed, then the softstart pump is turned off leaving the VFD pump under control. In both rising and falling demand there is a requirement to operate and coordinate the pumps during the transition. In a typical application which would have four transitions per day, only four or five minutes per day of duplicate operations, roughly 24 hours per year, or \$180 to \$200 per year in electrical cost differential between the two design and control strategies – cheap insurance against the potential damage..

Figure 3.

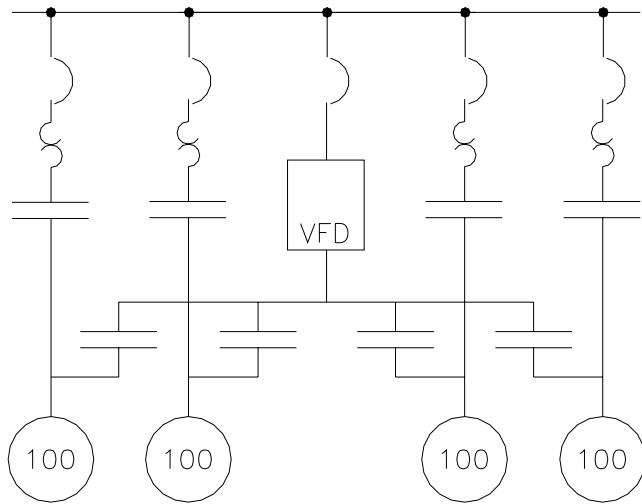
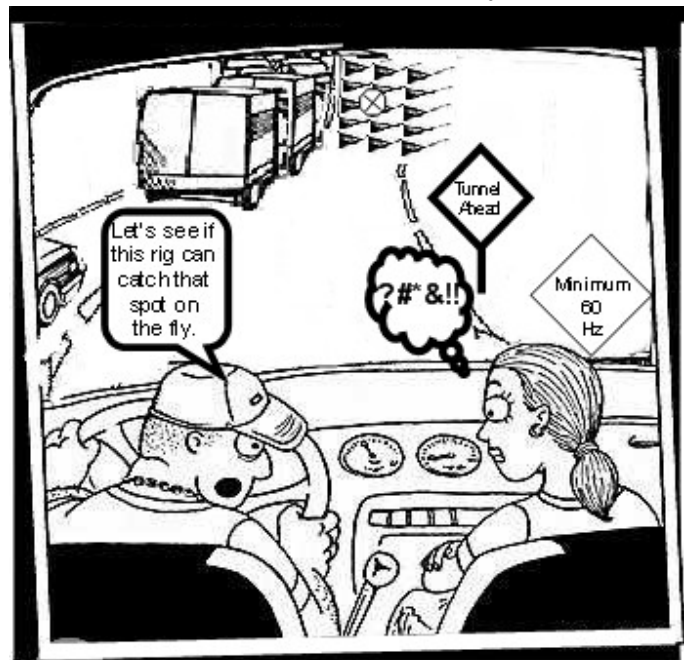

Figure 3 shows a smaller footprint, straightforward, lower cost design approach that addresses the transitions electrically with the functionality of drives available today. A single VFD is used to individually control any one of four motors then swap them while at full speed with across the line contactors. In the transition of adding a pump on-line as demand increases, the VFD can synchronously transfer the first pump at full speed to the bypass contactor across-the-line with closed transition, then connect to the next pump to operate under control through its full range.⁹ In the transition of dropping a pump as demand decreases, the second VFD pump is slowed until it is no longer pumping, cut off, then the VFD

synchronously connects to the pump on bypass and takes its load under control at full speed. A not so obvious point of safety and control is the imperative that the transfer be done synchronously in the electrical sense, not just in a coordinated, timely fashion, using a closed transition not an open one. Powering a motor from two sources out of phase will cause an electrical fault, or if the phase differential is large enough, cause a literal melt-down of the motor and electrical hardware. An external synchronizing protective relay can be used, or with the more modern drives of some manufacturers, the synchronizing function and protective relay is an internal function. As a result of being able to change control to or from VFD and across-the-line without risk and without any electrical or electronic interruption, the best of both worlds is available. At full capacity, there are no energy losses to the VFD as it is not under load; 299kW to deliver 400 hp. At any given point in the operating range from minimum output of one motor to maximum output of all four, the energy losses and the accompanying cooling requirements are at most one VFD, 9 kW in the example given, and next to nil if all of the pumps are at full speed. There are energy savings to this approach which can be considerable in large motor sizes, but as important is the absence of any control gap during any transition, the smaller footprint of the system as a whole, a lower capital cost, and the protection of the system plumbing and hardware.



A key distinction in drive properties needs to be made to appreciate the differences between synchronized transitions (closed transition: make before break) of VFD control to and from across-the-line versus the so called “catch-on-the-fly” transitions which are open transitions (break before make). In synchronized transitions, there is a period of time, controllably small, when the motor has two power sources operating at the same synchronous frequency; in this

⁹ With proper programming and careful drive selection, different sized motors can be used in this arrangement, swapping full parameter sets during the transitions between one pump and the next.

closed transition, there is never a moment when the motor does not have power supplied. In the more common “catch-on-the-fly” transition, by definition an open transition, there is a period of time when there is no power supplied to the motor; depending upon the setup configuration and electronic capabilities, this period of time ranges from 250-300 milliseconds to as long as several seconds or even longer. Again, by definition, during this interval there is no power to the motor, but there is decaying load; the fluid flow from the pump is slowing down. In the example above, the motor output torque diminishes by about 1% every 10 milliseconds against the braking effect of line pressure such that at 40-50 psi, there is no output flow at 500 milliseconds, ½ second. If there is a hydraulic ballast tank (“hydrotank”), pressure tank, or significant gas bubbles in a liquid line, they actually speed up the decay because they become the supply of expanding motive force to close the check valve and brake the flow from the pump. With or without ballast, the higher the pressure, the faster the decay in the load; the larger the line size or the higher the flow rate, the more momentum of the volume in the line and the resisting pressure decreases faster at the pump. If this sounds confusing or complex, it is best summarized that nothing good happens when there is a momentary break in the power supply, and it only gets worse if you try to minimize the time; either eliminate the gap altogether, or start and stop the pumps and motors slowly and let the water or air consumer endure the inconvenience.

In all cases, the motor slows down and its torque output decreases when the power supply is removed; the rate that it slows down varies dependent upon the load and circumstances of the moment, which is different for each and every occurrence. The greatest electrical risk is an unsynchronized handoff from the VFD to across-the-line, hazardous by all standards. **UNDER NO CIRCUMSTANCES SHOULD A CLOSED TRANSITION FROM A VFD TO AN ENERGIZED SOURCE BE ATTEMPTED WITHOUT ELECTRICAL SYNCHRONIZATION.** Attempts to transition from an across-the-line contactor or softstart to VFD control with “catch-on-the-fly” technology can be rationalized as flow requirements ramp down, but the risk of hydraulic damage must be considered. As shown in Figure 4, the open transition between sources results in a negative spike in pressure and flow which is quickly followed by a second positive spike if the check valve slams shut; either or both of these pressure waves easily reach hundreds of psi in systems of any size and place fittings, restraints, and piping at risk. Figure 5 shows the control profile of a single drive used to manage four pumps up and down the course of flow demand. Because the motors never lose power in a synchronized closed transition transfer from one pump to the next, there is no fluctuation of pressure or flow, and thus no risk of damage.

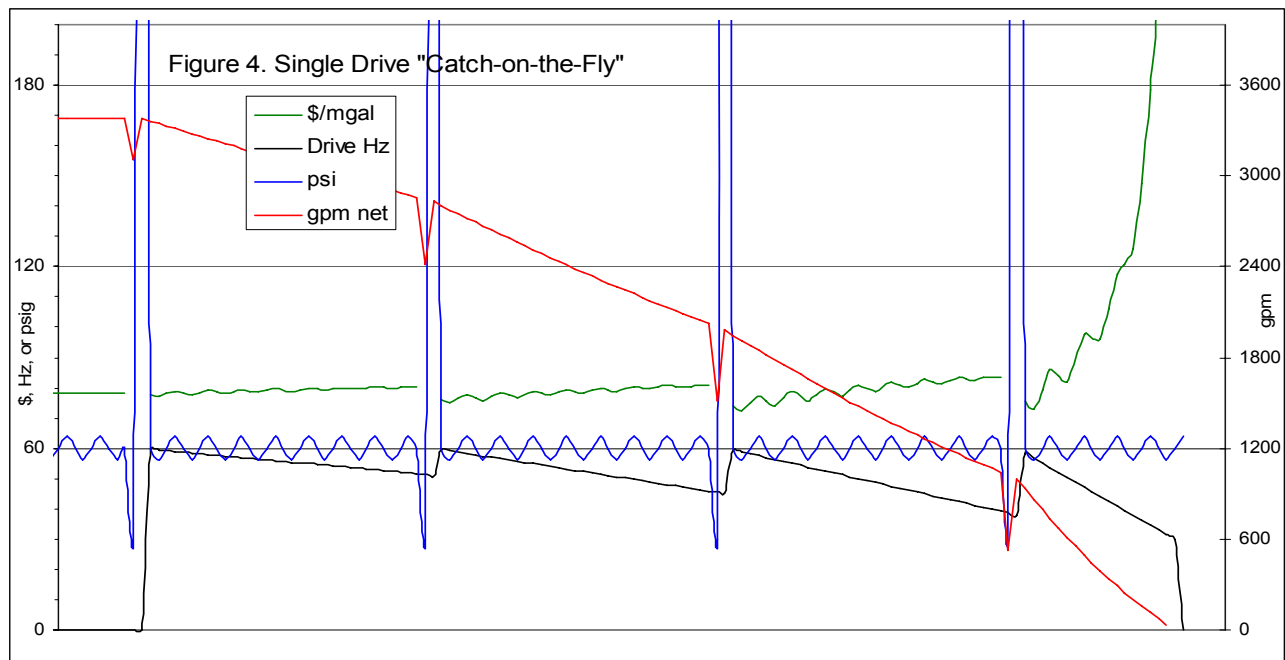

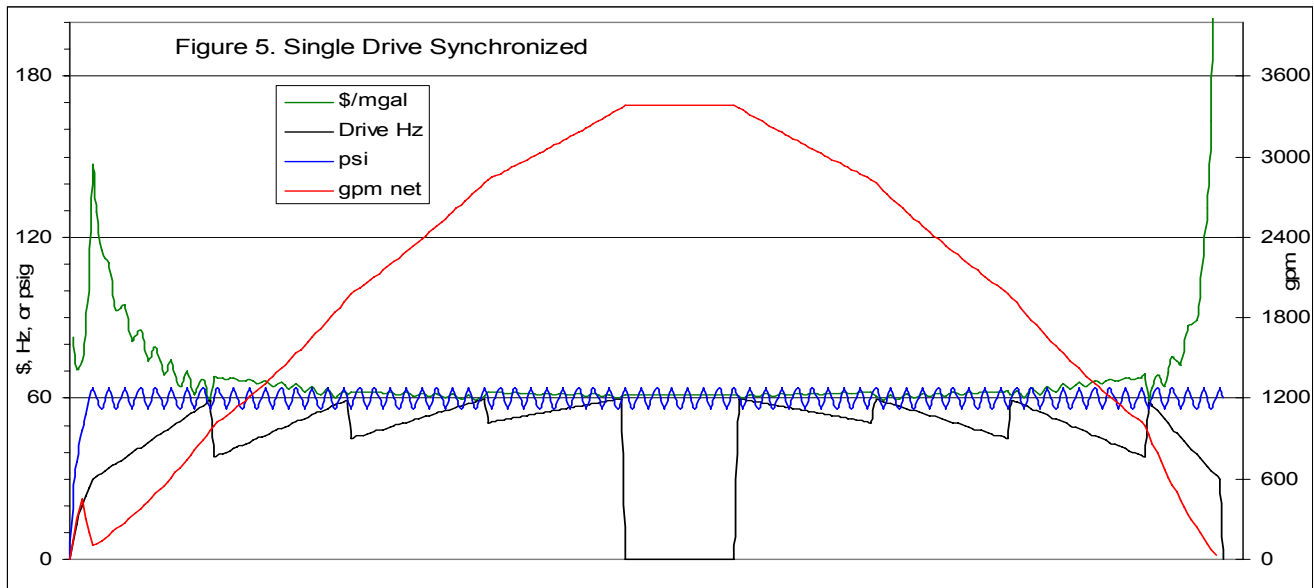

For certain, even with the most intelligent “catch-on-the-fly” technology which may sense and predict the voltage differentials and frequencies to protect the DC bus and internal electronics, there is the very real fact that the frequency of the power source and the frequency of any residual current or voltage on the decaying load side cannot be the same – it is literally impossible. The degree of risk taken trying to use “catch-on-the-fly” technology to transition motors to and from VFD and across-the-line is a matter of timing, relative magnitudes – and circumstances beyond control. One lesser known circumstance is that VFD output at 60 Hz and line power at 60 Hz are not normally in sync by virtue of the VFD functional mechanism, so much so that simply closing the contactor to add the unsynchronized second source is guaranteed to cause an electrical train wreck – in the best case cumulative heat damage, in the worst, lots of catastrophic arcs and sparks. Literally to add fuel to the train wreck, the sudden change in torque output at the pump starts the damaging pressure wave down the line; a faster change is not necessarily better, given that the transition time is the divisor in determining the magnitude of the potential damage; a slower change is not necessarily better as the magnitude of the “instantaneous” difference is greater – and in all cases the difference in potential energy is translated to the hardware, be it motor, pump, or plumbing. The only risk free alternative is a synchronous transfer – a closed transition – between VFD output and across-the-line where the frequency of the drive is made to coincide with that of the mains source.

One common argument against the design shown in Figure 3 is the lack of redundancy available for the single VFD used. Selection of VFD’s with a high Mean Time Between Failure (MTBF) and a short Mean Time To Repair (MTTR) can mitigate this concern. For small motors, the contactors can be used to start and stop the individual motors while the VFD is being serviced. For intermediate and large motors, designs shown in Figures 6 and 7 can be used; the choice between is best a function of the MTTR for the VFD and the criticality of the control scheme as the softstart is generally smaller and lesser capital cost. As with all redundancy, these come at some capital cost and with increased footprint and consideration for not using both sources simultaneously.

Figure 6.

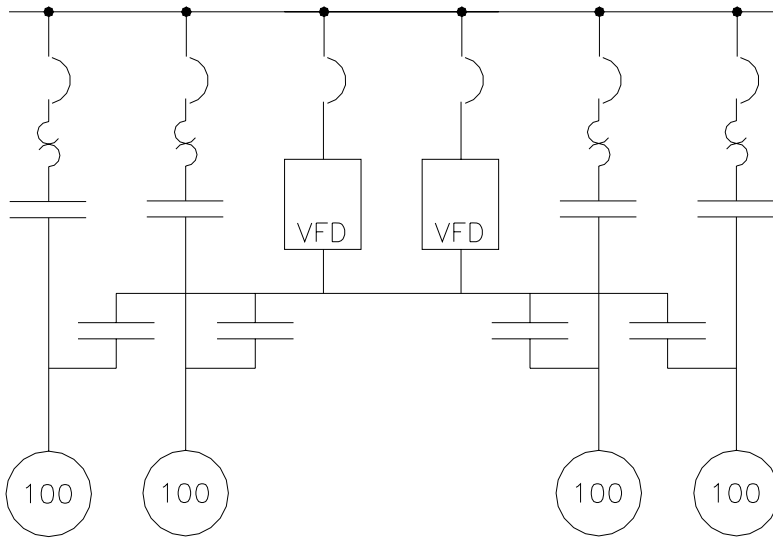
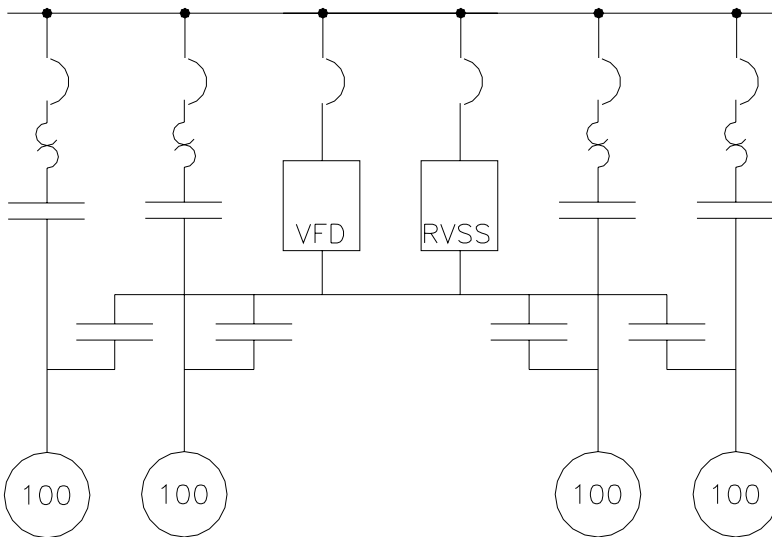

Figure 7.



More recent developments in drive technology provide for further reductions in the footprint of multiple motor load systems and are especially applicable when the multiple loads are of varying sizes or in large numbers providing different, even unrelated, services. Note in Figure 3 the need for 5 breakers and multiple contactors to supply the VFD and each of the motors. These take up valuable real estate with more copper and more connections, especially in high kW systems. The “typical” VFD is composed of three basic functions, converting AC power into DC, a DC buss, and converting DC power into controlled AC of differing frequency and/or voltage. VFD’s assembled from separate components are available as shown in Figure 8. A single, albeit larger, breaker feeds a single AFE (Active Front End) which in turn supplies a common DC buss. Multiple output converters provide individual power and individual control to each motor load. Within the smaller footprint is the individual control that may be required for multiple motor applications and this design is certainly applicable where multiple motor sizes are dictated by a wide range of

demand or diversity of services. The downside of this application is only the efficiency losses to heat of the drive itself, typically 3-4%, since power factor correction with no harmonics is available from the AFE. If footprint is more critical than the increased operating costs of about 6%, this design may well be preferred over synchronized transfer with across-the-line contactors. Redundancy can be addressed by having a second AFE to supply the DC buss, or for near complete redundancy, the design shown in Figure 9 can be used that allows for service on any of the individual components.

Even more significant energy savings can be had in addition to the obvious benefits of variable frequency drives by careful selection of the drive and its management of power factor; again, careful due diligence in the design and procurement is required, but the majority of municipal power bills are reduced by improving the power factor.^{10,11} The European Norm EN61000-3-2 has been

¹⁰ “Fact Sheet: Reducing Power Factor Cost; Document # US DOE/GO-10096-286, 1996 “

¹¹ In the author’s experience at over 20 facilities in six states (FL, GA, SC, KY, OH, CT) only one municipal billing was not significantly affected by improving the site’s power factor. Imperative in reviewing any opportunity for power factor cost

Figure 8.

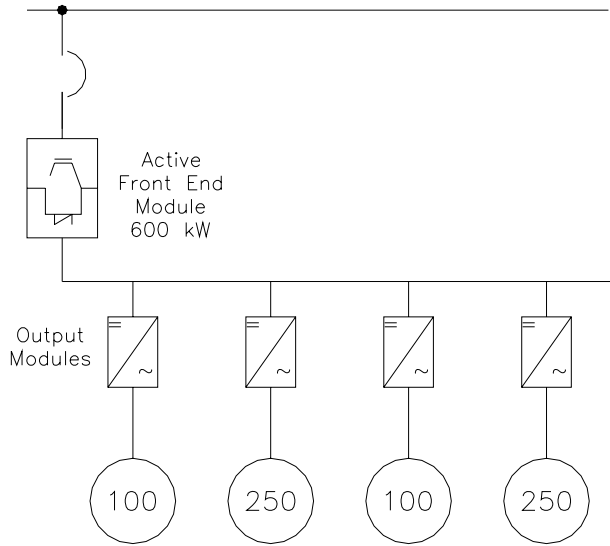
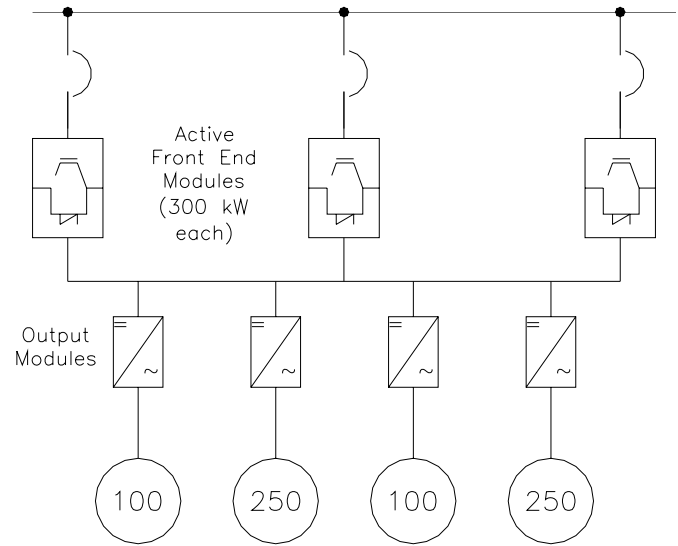

Figure 9.



established which requires reduction of the harmonics and power factor correction for all devices larger than 80W (1/10 hp).¹² This is essentially a mandate to reduce your power bill, and in so doing, reduce the power supply requirements of the power industry. Active Front End (AFE) technology which utilizes IGBTs (Insulated Gate Bipolar Transistors) can manipulate the phasing of voltage and current consumption to give a power factor of unity without the penalty of harmonics. Most new premium efficiency motors, circa 2005 and later, have a power factor of greater than 0.90 while many older motors and most rebuilt motors, have a power factor less than 0.80. This “minor” distinction is the difference between an electric bill for 111% of the actual power used versus 125% of the actual power used. Correcting the power factor to unity (1.0) with the same device is to implement better control and system performance and is both the intelligent and the practical choice.

Conclusion

No one control and electrical design is right for every application; economics are a reality. With advances in variable frequency drive technology now in their third and fourth generation, choices are available which can deliver real efficiency in terms of the power bill to be paid and protect the larger capital investment of pipes, valves, and hardware from inappropriate control. The application of fewer drives in combination with synchronized transition to and from across-the-line operation offers a lower capital cost, smaller footprint, AND more energy efficient approach than ever before with proven, common sense technology. With careful selection, operating cost reductions of 25 – 30% are immediately available. In the case of single 100 hp motor system at \$0.10/kWh, that’s almost \$20,000 per year at \$85,300 versus \$65,500; for an annual average 1 MW consumer, even 20% cost reduction is \$175,000 annually off of a bill of \$876,000. With careful selection, the Return On Investment is 1 to 3 years, and existing infrastructure is protected with quality performance.

Gene E. Keyser, Ph.D.
Key Solutions, Inc.
doc@key-solutions-inc.com

reduction is an awareness of the billing structure, how power consumption and power factor are measured, reported, and billed.

¹² See introduction and discussion of the fundamentals in the “Power Factor Correction Handbook”, available online at http://www.onsemi.com/pub_link/Collateral/HBD853-D.PDF.